

FRENCH REPUBLIC

The Ministry of Agriculture, Agri-food and
Food Sovereignty

Order of xx xxxx 2026 amending the Order of 28 March 2022 on the national type approval and individual approval of agricultural and forestry tractors belonging to one of the categories mentioned in Article 8 of Decree 2005-1236 of 30 September 2005

NOR:

Public concerned: *manufacturers, importers, rental companies, sellers, exhibitors and users of agricultural or forestry tractors.*

Purpose: *amendment of the Order of 28 March 2022 on the national type approval and individual approval of agricultural and forestry tractors belonging to one of the categories mentioned in Article 8 of Decree 2005-1236 of 30 September 2005. The amendment extends the transitional period for older type-approved agricultural tractors in categories T4.1 and T4.2 and updates the normative references in Annex III.*

Entry into force: *The text shall enter into force on the day after its publication.*

Application: *This Order is issued pursuant to Article 8 of Decree No. 2005-1236 of 30 September 2005 on the rules, requirements and procedures applicable to agricultural or forestry tractors and their devices.*

The Minister for Agriculture, Agri-food and Food Sovereignty and the Minister delegate for Industry under the Minister for Economy, Finance and Industrial, Energy and Digital Sovereignty,

Having regard to Regulation (EU) No. 167/2013 of the European Parliament and of the Council of 5 February 2013 on the approval and market surveillance of agricultural and forestry vehicles;

Having regard to Directive (EU) 2015/1535 of the European Parliament and of the Council of 9 September 2015 laying down a procedure for the provision of information in the field of technical regulations and of rules on Information Society services (codification);

Having regard to the Labour Code, particularly Articles R4311-1, R4311-7, R4312-1-1 and R4313-75 thereof;

Having regard to Decree No. 2005-1236 of 30 September 2005, as amended, relating to the rules, requirements and procedures applicable to agricultural or forestry tractors and their devices;

Having regard to Decree No. 2009-697 of 16 June 2009 on standardisation, particularly Article 17 thereof;

Having regard to the Order of 28 March 2022 on the national type approval and individual approval of agricultural and forestry tractors belonging to one of the categories listed in Article 8 of Decree 2005-1236 of 30 September 2005;

Having regard to notification No. 2026/XXX/FR sent to the European Commission on .././.....;

Having regard to the information from the specialised committee on agricultural activities of the Working Conditions Guidance Council of 17 February 2024,

Hereby order:

Article 1

In the third sentence of the second subparagraph of Article 15 of the aforementioned Order of 28 March 2022, the number: '5' is replaced by the number '8'.

Article 2

Annexes II and III in the 'Annexes' section of the same Order are replaced by two Annexes, II and III, worded as follows:

'Annex II

A - ASSESSMENT CRITERIA FOR CONFORMITY TO NATIONAL TYPE APPROVAL

The numbering of the items corresponds to Annex II to Decree No. 2005-1236, as amended, and the correspondence with those in Annex I of Regulation (EU) No. 167/2013 referred to above is indicated for information purposes.

Annex II to the Decree		Annex I to the Regulation	Requirements	Categories of vehicles			
				T4.1	T4.2	C4.1	C except C4.1
1	Roll-over protection	35	Regulation No. 1322/2014, Annex VI	N/A	A	N/A	N/A
		36	Regulation No. 1322/2014, Annex VII	N/A	N/A	N/A	A
		37	Regulation No. 1322/2014, Annex VIII	N/A	A	N/A	A
			Appendix A to Annex III	A	N/A	A	N/A
2	Driver's seat	43	Regulation No. 1322/2014, Annex XIV (component)	X	X	X	X
			Regulation No. 1322/2014, Annex XIV (installation)	A	A	A	A
		47	Regulation No. 1322/2014, Annex XVIII	A	A	A	A

		48	Regulation No. 1322/2014, Annex XIX	A	A	A	A
3	Noise level	42	Regulation No. 1322/2014, Annex XIII	A	A	A	A
4	Operating space and access to the driving position	44	Regulation No. 1322/2014, Annex XV	A	A	A	A
5	Power take-offs	45	Regulation No. 1322/2014, Annex XVI	A	A	A	A
			Appendix B to Annex III	A	A	A	A
6	Installation, position, operation and identification of the controls	52	Regulation No. 1322/2014, Annex XXIII	A	A	A	A
		55	Regulation No. 1322/2014, Annex XXVI	A	A	A	A
7	Protection of drive components	46	Regulation No. 1322/2014, Annex XVII	A	A	A	A
		50	Regulation No. 1322/2014, Annex XXI	A	A	A	A
		57	Regulation No. 1322/2014, Annex XXVIII	A	A	A	A
		53	Regulation No. 1322/2014, Annex XXIV	A	A	A	A
8	Mechanical couplings for towing	34	Regulation No. 2015/208, Annex XXXIV (component)	X	X	X	X
			Regulation No. 2015/208, Annex XXXIV (installation)	A	A	A	A
9	Braking**	3	Regulation 2015/68	A	A	A	A
10	User manual	51	Regulation No. 1322/2014, Annex XXII	A	A	A	A

	seat		Annex XIV (component)								
			Regulation No. 1322/2014, Annex XIV (installation)	B*	B*	B*	B*	B*	B*	B*	B*
		47	Regulation No. 1322/2014, Annex XVIII	B	B	B	B	B	B	B	B
		48	Regulation No. 1322/2014, Annex XIX	X	X	X	X	X	X	X	X
			SécuTrac© software	D	D	D	D	D	D	D	D
3	Noise level	42	Regulation No. 1322/2014, Annex XIII	B	B	B	B	B	B	B	B
4	Operating space and access to the driving position	44	Regulation No. 1322/2014, Annex XV	A	A	A	A	A	A	A	A
5	Power take-offs	45	Regulation No. 1322/2014, Annex XVI	A	A	A	A	A	A	A	A
			Appendix B to Annex III	B	B	B	B	B	B	B	B
6	Installation, position, operation and identificati on of the controls	52	Regulation No. 1322/2014, Annex XXIII	A	A	A	A	A	A	A	A
		55	Regulation No. 1322/2014, Annex XXVI	A	A	A	A	A	A	A	A
7	Protection of drive components	46	Regulation No. 1322/2014, Annex XVII	A	A	A	A	A	A	A	A
		50	Regulation No. 1322/2014, Annex XXI	A	A	A	A	A	A	A	A
		53	Regulation No.	A	A	A	A	A	A	A	A

			1322/2014, Annex XXIV								
		57	Regulation No. 1322/2014, Annex XXVIII	A	A	A	A	A	A	A	A
8	Mechanical couplings for towing	34	Regulation No. 2015/208, Annex XXXIV (component)	X	X	X	X	X	X	X	X
			Regulation No. 2015/208, Annex XXXIV (installation)	B	B	B	B	B	B	B	B
9	Braking**	3	Regulation 2015/68	A	A	A	A	A	A	A	A
10	User manual	51	Regulation No. 1322/2014, Annex XXII	A	A	A	A	A	A	A	A
			Appendix C to Annex III	N/ A	N/A	N/A	A	N/A	N/A	A	N/A
11	Passenger seat	41	Regulation No. 1322/2014, Annex XII	B	B	B	B	B	B	B	B
12	Falling objects protection	40	Regulation No. 1322/2014, Annex XI	B	B	B	B	B	B	B	B
			SécuTrac© software	D	D	D	D	D	D	D	D
13	Protection against penetrating objects	49	Regulation No. 1322/2014, Annex XX	B	B	B	B	B	B	B	B
14	Prevention of contact with hazardous substances	59	Regulation No. 1322/2014, Annex XXIX	A	A	A	A	A	A	A	A

Annex II key	
X	Full compliance with the regulatory act is required. The EU type-approval certificate is issued when required by Regulation (EU) No. 2015/504. Production conformity shall be ensured.
A	The type-approval certificate and type-approval mark are not required. Depending on the regulatory act concerned, test reports must be issued by a technical service notified by France.
B	The technical requirements of the regulatory act must be met. The tests provided for in the regulatory act must be performed in full; subject to the agreement of the approved technical service, they may be performed by the applicant in person, who then issues the technical report. With the agreement of the approved technical service, the applicant may demonstrate compliance with the requirements of the regulatory act by using technical specifications with an equivalent effect.
D	A declaration of conformity submitted by the applicant is sufficient. No test report is required.
I	Identical to T according to the category.
*	The EU type-approval certificate for components and separate technical units shall be issued when provided for in Regulation (EU) 2015/504. Production conformity shall be ensured.
**	The requirements of the Order of 19 December 2016, as amended, have an equivalent effect.
	As an alternative, for tractors whose maximum speed is less than or equal to 25 km/h, application of the Order of 18 August 1955, as amended, provides conformity.
N/ A	Not applicable

'A supporting document demonstrating conformity to a level higher than the required level is accepted.

Levels of supporting documents in descending order: X, A, B and D.

'Annex III

Appendix A

ROLL-OVER PROTECTION STRUCTURES OF TRACTORS IN CATEGORY T4.1/C4.1

Tractors in category T4.1 or C4.1 (known as "high-clearance") shall meet the requirements for continuous stability and non-overturning and shall be fitted with a roll-over protection structure, in accordance with Standard NF U02-052-1: 2024.

Appendix B

PROTECTIVE GUARDS OF POWER TAKE-OFFS

1. Impact test at freezing temperatures for protective plastic guards.

1.1. Keep the guard at -35 °C for at least one hour before starting the test.

Take measurements to ensure the temperature of the guard does not rise above -35 °C during the test.

1.2. With the guard at -35 °C, strike a centred blow perpendicular to the end of the power take-off (PTO) shaft with an impact energy of 98 J using an impact pendulum, as shown in Figure 9. The contact surface must be flat and have a diameter of 50 mm, and the radius of the edge of the contact surface must comply with Figure 9.

Figure 8: impact testing

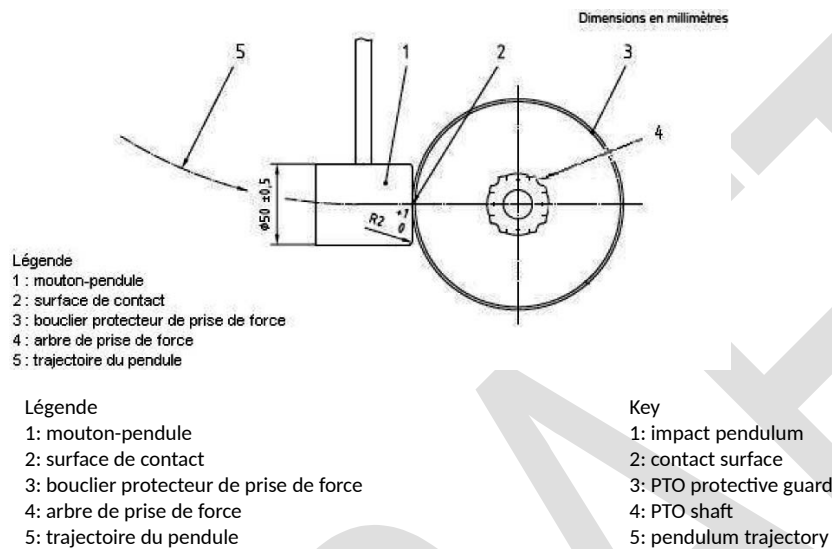

The protective guard of the power take-off shall be considered to have passed the test if it does not have any holes or deformations leaving the shaft unprotected and if it does not have any fractures, cracks or separation of its component parts. Scratches caused by the edge of the impact pendulum are permitted.

2. Position of the power take-off: if the height of the power take-off shaft from the ground is greater than 1 300 mm, a boarding means shall be provided that complies with the requirements of Chapter 4 of Annex XV to Regulation (EC) No. 1322/2014. This requirement does not apply to power take-offs used to drive equipment whose assembly and disassembly requires specific means such as lifting apparatuses or external access to the tractor.

Appendix C

USER MANUAL FOR TRACTORS IN CATEGORY T4.1/C4.1

In addition to the specifications set out in Annex XXII to Regulation No. 1322/2014, the operating manual of category T4.1 or C4.1 tractors must include all of the information required under Standard NF U02-052-2: 2024. ‘

Article 3

The Secretary-General of the Ministry of Agriculture, Agri-food and Food Sovereignty and the Inter-ministerial Delegate for Standards shall be responsible, each within their own field of competence, for implementing this Order, which shall be published in the Official Journal of the French Republic.

Done on 2026.

The Minister for Agriculture, Agri-food and Food Sovereignty,
For the Minister and by delegation:

The Head of the Financial, Social and Logistics Affairs Department,
S. COLLIAT

The Minister delegate for Industry under the Minister for Economy, Finance and Industrial, Energy
and Digital Sovereignty,

For and on behalf of the Minister:

The Interministerial Delegate for Standards,
D. RUEL

DRAFT